

AILERONS - MAINTENANCE PRACTICES

1. General

- A. An aileron is attached to the trailing edge of each wing. Both the right and left ailerons have an aileron trim tab that is attached to the aileron by piano-type hinges.

2. Aileron Assembly Removal/Installation

- A. Remove the Aileron Assembly (Refer to Figure 201).
- (1) Remove the wing tip. Refer to Wing Tip - Removal/Installation.
 - (2) Remove the attach bolt and aileron push-pull rod.
 - (3) Remove the aileron trim-tab-hinge pin retaining screw, the screws, and the cover.
 - (4) Disconnect the aileron trim-tab-push-pull rods at the attach bracket.
NOTE: If the right aileron is to be removed, the push-pull rods are attached to the aileron trim-tab-actuator push-pull rods.
 - (5) Remove the aileron hinge bolts and remove the aileron. Be careful not to cause damage to the ground strap connector.
- B. Install the Aileron Assembly (Refer to Figure 201).
- (1) Put the aileron assembly in position until the inboard and outboard hinge holes align with the wing hinge bearings. Install the outboard and inboard aileron bolts into the wing hinge bearings. Install one nut with a cotter pin on the inboard bolt. Install safety-wire on the outboard bolt as shown in Chapter 20, Safelying - Maintenance Practices.
 - (2) Connect the aileron trim tab push-pull rods to the attach bracket.
 - (3) Install the cover with the attach screws.
 - (4) Install the trim tab-hinge-pin retaining screw through the loop in the outboard end of the hinge pin.
 - (5) Connect the aileron push-pull rod to the aileron with the attach bolt. Torque the attach bolt as shown in Chapter 20, Torque Data - Maintenance Practices.
 - (6) Install the wing tip. Refer to Wing Tip - Removal/Installation.
 - (7) Examine the aileron and aileron-trim-tab cable tensions and travels in accordance with Chapter 27, Aileron and Spoiler System - Adjustment/Test. Adjust the rigging as necessary.

3. Aileron Trim Tab Removal/Installation

- A. Remove the Aileron Trim Tab (Refer to Figure 201).
- (1) Remove the wing tip. Refer to Wing Tip - Removal/Installation.
 - (2) Remove the trim tab hinge pin retaining screw, the screws, and the cover.
 - (3) Disconnect the trim tab push-pull rods with the removal of the cotter pins, castellated nuts, and bolts. Keep the bushings.
 - (4) Remove the hinge pin from the hinge and remove the trim tab.
- B. Install the Aileron Trim Tab (Refer to Figure 201).
- (1) Put the trim tab into the aileron cutout, align the hinge half holes and install the hinge pin.
 - (2) Align the holes in push-pull rod clevises with the holes in the trim tab horns. Install the bushings, bolts, and nuts. Safety the nuts with cotter pins.
 - (3) Install the cover with screws.
 - (4) With the loop of the hinge pin under the head of the retaining screw, tighten the screw.
 - (5) Install the wing tip. Refer to Wing Tip Removal/Installation.

Figure 201 : Sheet 1 : Aileron Installation

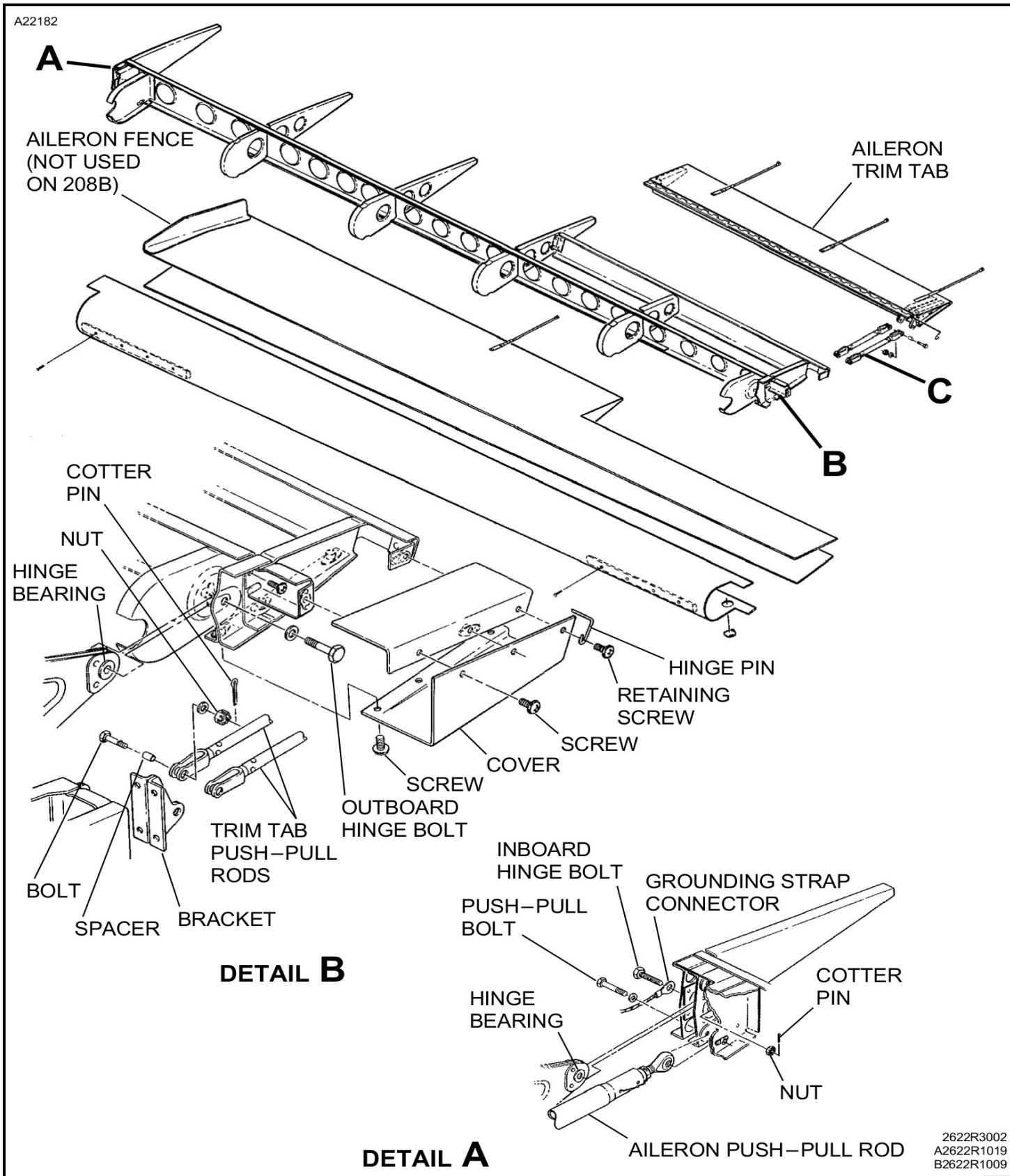

Figure 201 : Sheet 2 : Aileron Installation

